

ETA SH 20 to 60 kW  
ETA SH-P with TWIN  
20 + 30 kW (SH-P)  
20 + 26 kW (TWIN)



The log or combination boiler  
for more flexibility



## USAGE AREA



## Exactly the way I want it

Heating with wood is – even if you don't have your own forest – extremely economical. It doesn't damage the climate, strengthens the local economy and is crisis-proof, as wood is freely available in Europe.

A modern log boiler is highly effective. Normally, you only have to add fuel once a day, on very cold days maybe twice. Unlike pellet or woodchip boilers, a standard log boiler does not run fully automatically.

### **Affordable and convenient**

ETA has the ideal solution for those who want to use extremely affordable wood as a heating fuel and still want to enjoy the full benefits of effortless automation. The ETA TWIN consists of two fully-

fledged boilers that perfectly complement each other. The ETA SH log boiler is available with an optional flange that connects easily to a fully automated pellet burner – years later without converting the heating system or chimney connection.

### **Intelligent system**

The ETA TWIN boilers work perfectly together. If the fuel runs out in the log boiler it will let you know. If over a freely selectable time period no fuel is added, the pellet boiler automatically takes up the work – until you add fuel again to the log boiler. So your home stays warm even if you are not there for some time.

# A win-win situation

Save heating costs, strengthen your local economy and look after the environment in the process: heating with wood is worth it. Wood continuously regrows in our forests, thus it is crisis-proof and economical. The amount of forested land across Europe is increasing every year.

The natural raw material is CO<sub>2</sub>-neutral, this means that during its combustion no more CO<sub>2</sub> will be released than the tree took in during its growth. The same amount will also be released if the wood rots in the forest. So heating with wood doesn't burden our climate.

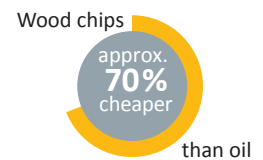
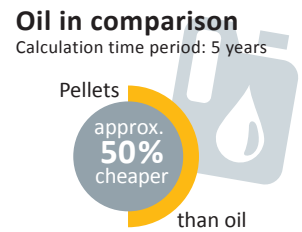
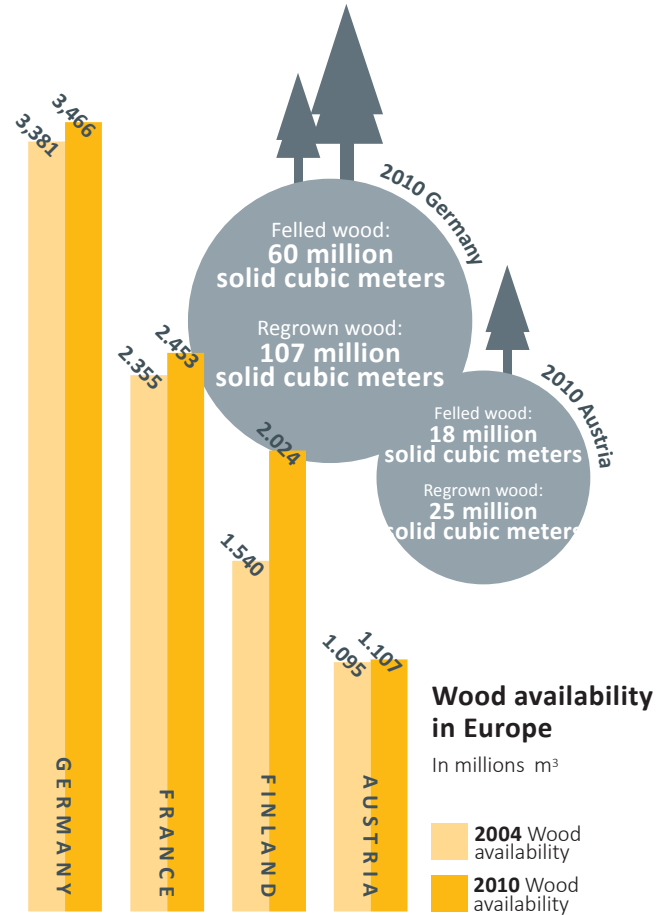
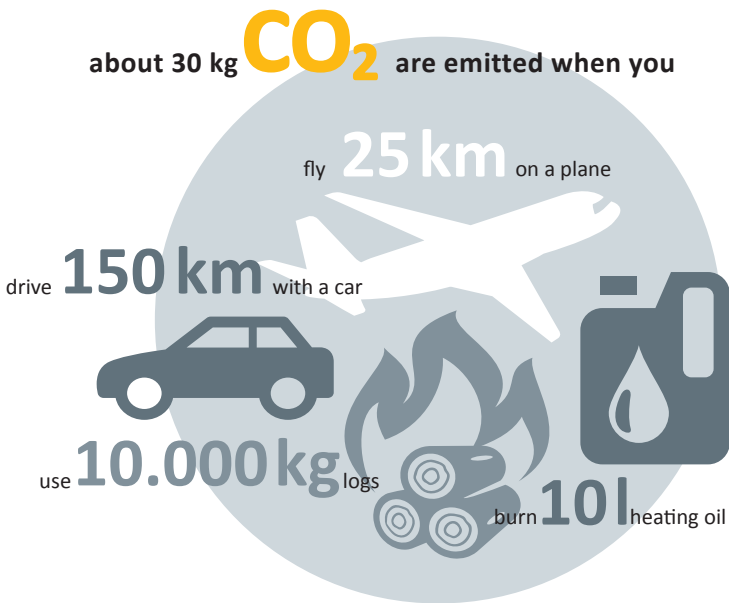

While the price of fossil fuels such as oil and gas are subject to significant fluctuations in the international markets and will certainly rise long-term, the price of wood and pellets are reliable.

**Fuel costs: oil and pellets in comparison**  
2 tonnes of pellets roughly correspond to 1,000 l of heating oil

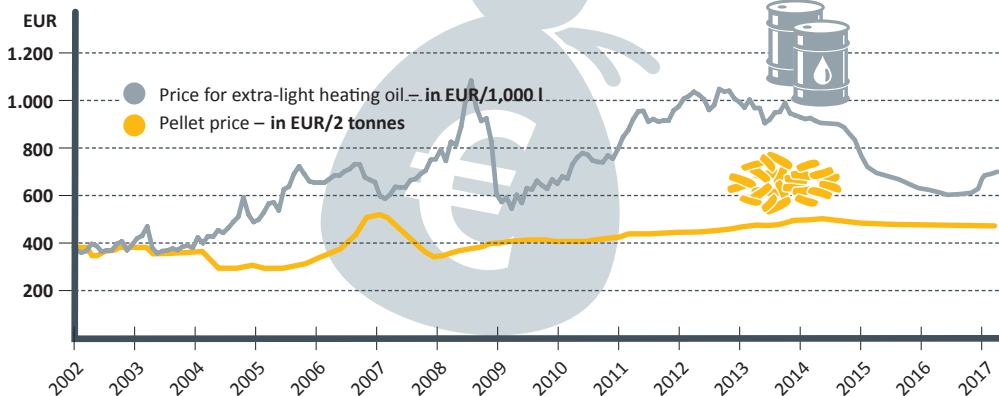

# Effortless wood heating

No log boiler runs fully automatically, but the ETA SH takes away a large part of the work. Refilling without kindling and paper, cleaning the heat exchanger with just a handle and de-ashing from the front are just some of the most important user friendly features.

## Starting a boiler made simple

You open the outer insulated door. The draught fan starts up automatically and quietly if its not working already, to transport enough oxygen into the combustion chamber. When you open the fuel chamber door to add half metre logs, the draught fan activates the carbonization gas extraction situated directly above the fuel chamber door. It ensures that no smoke or odour escapes from the open boiler. You add fuel. The fuel chamber accommodates enough logs to ensure that replenishment is only necessary once a day, or sometimes twice on very cold days. The new wood burns with the embers from the remaining fire. You don't need paper, no fine chips, no kindling – not

*Remote controlled via the meinETA communication platform.*



even automatic ignition is required. You close the door and pull – in passing – on the cleaning lever two or three times: the heat exchanger is clean again and thus operating very efficiently. You only remove the ash as needed. Sounds easy? It is! Heating with wood could hardly be more user-friendly!

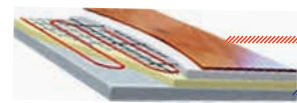
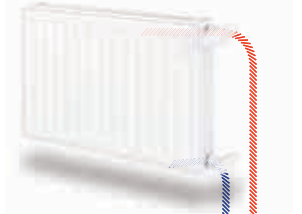

## Ready for anything

The ETA SH is more than a log boiler - or in the TWIN version a log and pellet boiler. With it you have your entire heating and hot water supply under control – and everything is perfectly coordinated.

### You can integrate the following into your boiler management:

**1 Solar heating system:** with a collector surface of just 8 to 12 m<sup>2</sup>, on sunny days all of the hot water is heated by free solar energy. With the ETA stratified charging module, the solar heating system can be perfectly linked to the system.

*The ETA mixing circuit module for two heating circuits saves a lot of time and money during installation, as no sensor lines, pumps or mixer cables have to be installed.*

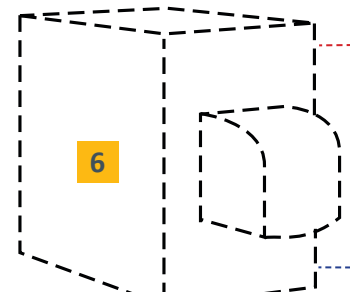
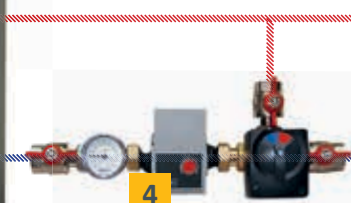

**2 Buffer:** A buffer is a must for log-burning heating. The fire in the boiler can only be reduced slowly. On warmer days, above all in autumn and spring, more heat is produced than is needed for heating. It can be stored in the buffer and then utilised when needed. You then add fuel when you have time – totally stress-free! In the summer the boiler only has to work every few days, maybe once a week with the instantaneous hot water module, so that enough hot water is prepared for the rest of the time.

**3 The ETA buffer management** along with the load reduction on start up ensures that your house is heated especially quickly. The potential available residual heat from the buffer additionally accelerates the start-up.

**4 The automatic return riser with mixer** protects the boiler against corrosion and saves energy, so that the residual heat can also still be optimally used at the end of the firing phase.



**5 Instantaneous hot water module:** It only needs a bit of space, because it can be built into the buffer storage tank or hung on the wall. It instantly prepares the hot water for showering, drinking or dishwashing using mains water, rather than stored hot water, so ensures the most clean and hygienic hot water. Of course a conventional hot water tank can be integrated into the boiler system instead.

**6 Additional boiler:** Oil, gas or further pellet boilers can also be integrated in the ETA system. These are simply started from the wood boiler.

#### ETA tip:

Fuel chamber content of the combustion chamber x 10 = minimum required buffer volume.

Fuel chamber content of the combustion chamber x 15 = optimum buffer volume for best energy utilisation and ideal temperature.

If your boiler room is not high enough for a buffer, you can easily connect two smaller ETA buffer tanks together.

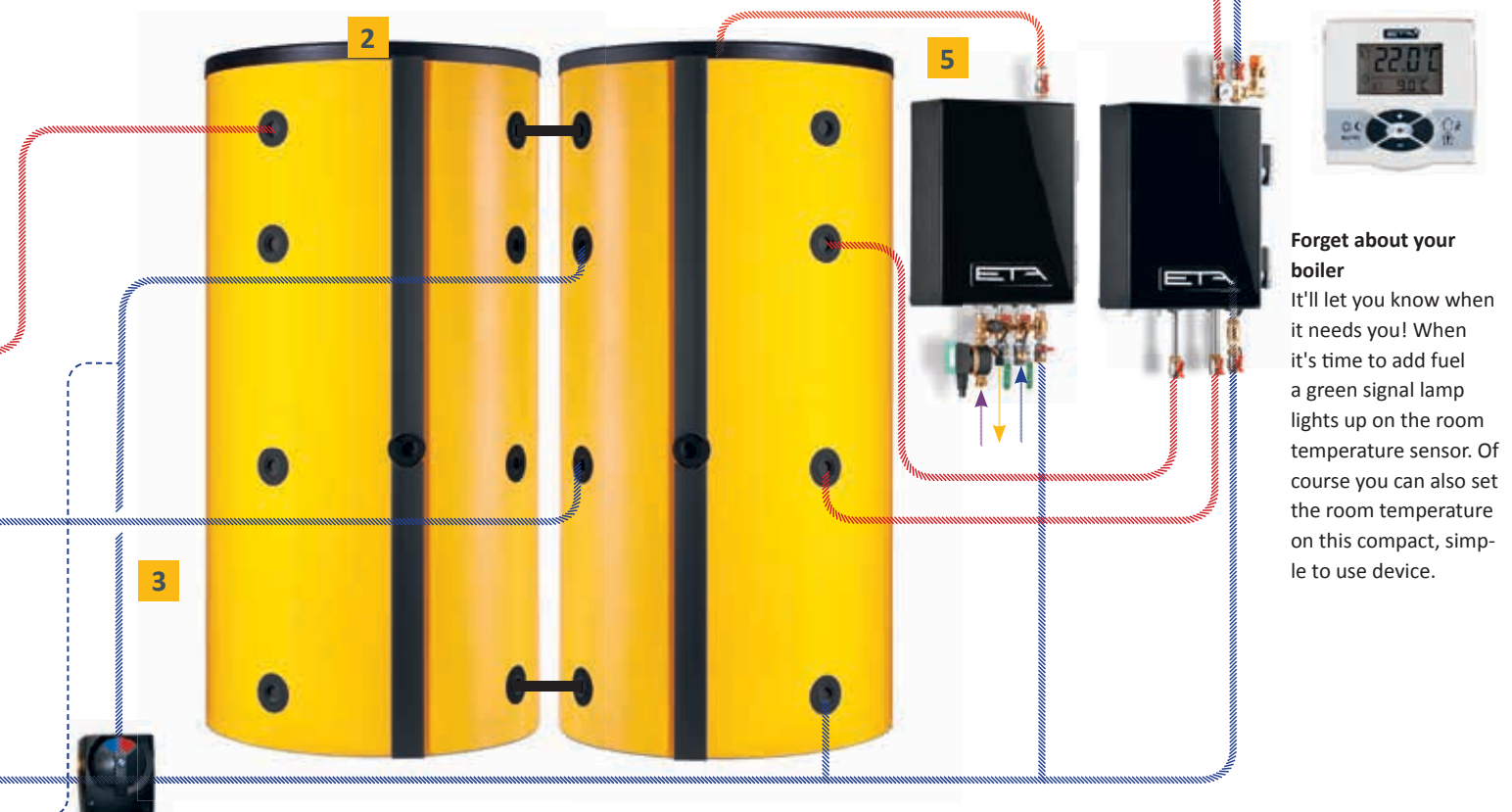

#### Forget about your boiler

It'll let you know when it needs you! When it's time to add fuel a green signal lamp lights up on the room temperature sensor. Of course you can also set the room temperature on this compact, simple to use device.

## Efficiency is in the air

The better the combustion functions, the higher the efficiency and the lower the emissions. Oxygen is needed for this in differing amounts depending on the wood and its level of dryness. The ETA combustion control system is a finely tuned system that precisely regulates the oxygen supply and, therefore, the temperature in the combustion chamber.



### Draught fan

**Safety and efficiency.** Quiet as a whisper, this speed-controlled fan ensures underpressure in the boiler. No matter how full the fuel chamber is, you can add fuel at any time – and completely without danger. As soon as you open the boiler door, the draught fan automatically switches on and thus prevents combustion gas from escaping. Additionally, the draught fan ensures oxygen supply in the combustion chamber and therefore ideal burning behaviour and best utilisation of the fuel.

### Two automatic air flaps

**Always the right amount of air.** Two automatic air flaps regulate the primary and secondary air supply totally according to demand. This means there is never too little oxygen in the combustion chamber and the fuel can always be fully utilised. The fact that there is never too much oxygen in the combustion chamber and the temperature can never be too high increases the lifetime of the boiler significantly.

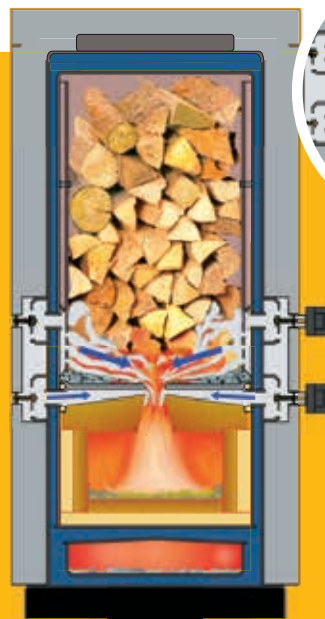



## Lambda probe

**The right mix.** Whether you heat with beech or spruce, supply large or small pieces of wood, the boiler is starting up or in full operation – ideal combustion always comes when the amount of supplied air is just right. The correctly placed lambda probe is the brains of the combustion technology, so to speak. It regulates how much oxygen is currently being used. The result: high efficiency and low emissions.



*The lambda probe is an important part of the combustion technology. In conjunction with the ETA combustion control system, it determines the course and quality of combustion.*



## Heat exchanger

**Best efficiency, easy cleaning.** Targeted air supply in the heat exchanger pipe ensure the highest efficiency and an even heat exchange. Cleaning virtually takes care of itself: Just pull the cleaning lever a few times in passing and the heat exchanger is already clean again. You don't have to open cleaning doors, nor do you come into contact with dirt.

**Even automatically, if needed.**

The heat exchanger can also be equipped with an optional drive. The heat exchanger is cleaned fully automatically with turbulators. This ensures consistently high efficiency and effortless heating.



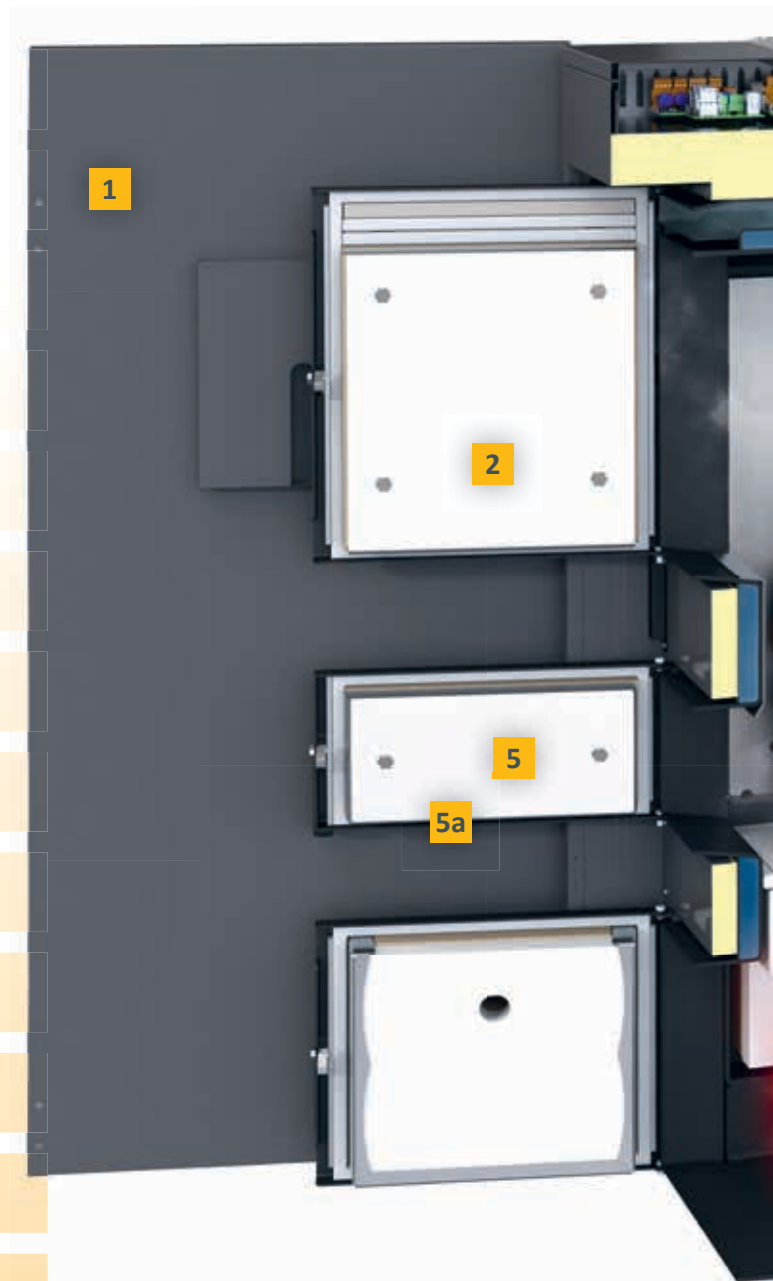

## The way to heat

Put in the wood, start the fire... No problem with the right technology if you want to achieve the highest efficiency for the lowest emissions. In the ETA log boiler, many components work together perfectly to achieve an optimum result and make heating as convenient as possible.

- 1 Insulation door:** Because you're looking to heat the living space and not the boiler room, the insulated outer door protects against heat loss - and does so very well.
- 2 Large fuel chamber doors:** so that adding wood is really simple!
- 3 Carbonization gas extraction:** It is active when you add fuel and ensures that gas never escapes when the fuel chamber doors are open.
- 4 Large fuel chamber:** With SH 20/30 the fuel chamber is 150 litres, with the SH 40/50/60 even 223 litres. That means that you only have to add fuel occasionally.
- 5 Ignition door:** If, for example, there are no more embers in the boiler, here you can easily and simply re-start the boiler.
- 5a Optional automatic ignition:** With the optional automatic ignition, a feature which can be easily retrofitted, split logs are ignited automatically.
- 6 Patented glow zone combustion chamber:** it is especially heat-resistant and fitted with expansion joints, so that no cracks occur due to temperature fluctuations.
- 7 Optional pellets flange for ETA SH-P 20/30:** For easy addition to the ETA TWIN Pellet burner.



### The way through the boiler:

-  Fuel
-  Flue gases
-  Heating water
-  Air





- 8 Draught fan:** Quiet as a whisper, this fan ensures underpressure in the boiler. Additionally, it controls the air quantity and thus ensures safety in the boiler room.
- 9 Cleaning lever:** It can be mounted either on the right or the left depending on space and your wishes. When you pull it occasionally, the heat exchanger is completely and automatically cleaned by the jogging motion. You don't have to open any cleaning doors and also won't get dirty in the process.
- 9a Optional automatic heat exchanger dedusting:** The heat exchanger is cleaned fully automatically with turbulators. This ensures consistently high efficiency and effortless heating.
- 10 Primary and secondary air flap:** both flaps are controlled via the lambda probe, so that the ideal amount of air always reaches the combustion chamber for combustion. Can optionally be mounted on the left or right.
- 11 Lambda probe:** Thanks to automatic signal calibration, it gets the best possible heating value from any wood.
- 12 De-ashing, cleaning and maintenance from the front:** This is not only comfortable but also makes setting up the boiler in small boiler rooms easy. There are no lateral doors for which additional space is needed.
- 13 Touchscreen:** the capacitive touchscreen can be adjusted to the individual operator's comfort by tilting or swivelling.





## Patented glow zone combustion chamber

Wood needs heat of up to 1,100 °C to burn completely and efficiently. To ensure that the combustion chamber can withstand this load over many years, not just the materials have to be of the highest quality but also the structure. It consists of several layers that are connected together by expansion joints. They prevent tension in the plates that can cause cracks due to temperature fluctuations.

Temperature-resistant cast iron grates guide the flames into the combustion chamber. They include air nozzles, which are required for complete combustion.

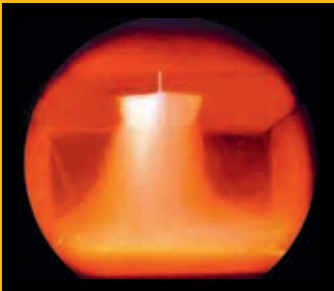

*From the thermal image it is clear how strongly the air-gas mix is swirled in the glow zone combustion chamber. This constant movement significantly contributes to a low-residue combustion.*

## Pellet flange for ETA SH-P 20/30:

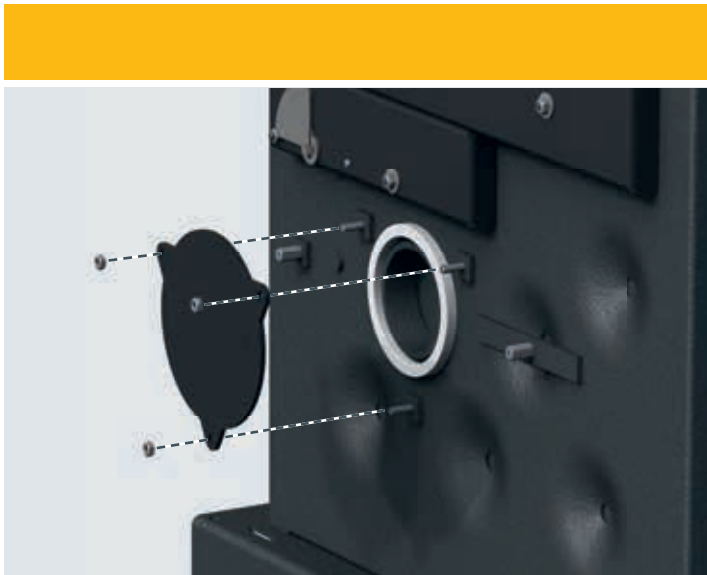

This optional addition makes heating flexible. If at any time you desire the fully automatic comfort of a pellet heating system, you only need to connect the ETA TWIN – both systems will work perfectly together. The burner can be attached to the left or right of the log boiler, depending on the room situation in the heating room, as the flange is available on both sides.

To upgrade the heating system, you don't need to make any changes to the heating system or to the chimney.



## ETAtouch, the touch-screen on the boiler

Confusingly arranged buttons and control systems are a thing of the past, because with the touchscreen of the ETA SH or SH-TWIN you can quickly and easily control all settings. The icons are self-explanatory. Whether combustion control, buffer management, hot water preparation, weather-compensated heating circuit controlled with a weekly program for two circuits, the yield of the connected solar heating system or monitoring all functions and drives: you click on the right symbols intuitively and completely without operating instructions.

Additionally, your boiler also has a LAN connection to connect to the internet. Whether from a smartphone, tablet or computer: you can control your heating from anywhere! If you wish your boiler can send you email messages. Free software



updates via USB connection. Furthermore, you are included in the meinETA partner network. So you can, for example, allow a technician to access your boiler control system. That saves travel and service costs!

## Ignition door

**Small door, lots of comfort.** Thanks to the ignition door you don't have to laboriously ignite the wood via the fill chamber door. No matter how much you have filled the boiler with combustible material: when heating up via the small door you don't need either kindling or ignition aids. Just a bit of paper is enough.

The ignition door is also extremely practical when cleaning the filling chamber. The ash can simply be removed via the grate with a poker without any problems.

*An automatic ignition is available as an option, which can be retrofitted.*



## Automatically simple

### Automatic cleaning for highest efficiency

The ash is automatically transported from the combustion chamber into the ash bin, which holds 16 litres. There it is compressed heavily so that the container only has to be emptied two to three times per heating season.

**Even the heat exchanger cleans itself** - fully automatically with turbulators. This guarantees the highest efficiency at all times!

### Automatic ignition of the pellet burner

The control system detects a heating request, but there are no more logs in the boiler... No problem! In this case the pellet burner switches on if you wish. Ignition occurs automatically.

**Control of the pellet burner:** If you don't want the pellet burner to switch on immediately when the heat requirement is no longer covered by the log burning boiler, the pellets automation can be delayed by up to 48 hours. The pellet operation can also be temporarily limited, namely to a defined time of day or to individual days of the week. All of this works via the intuitively operable touchscreen, mobile device, computer or tablet.

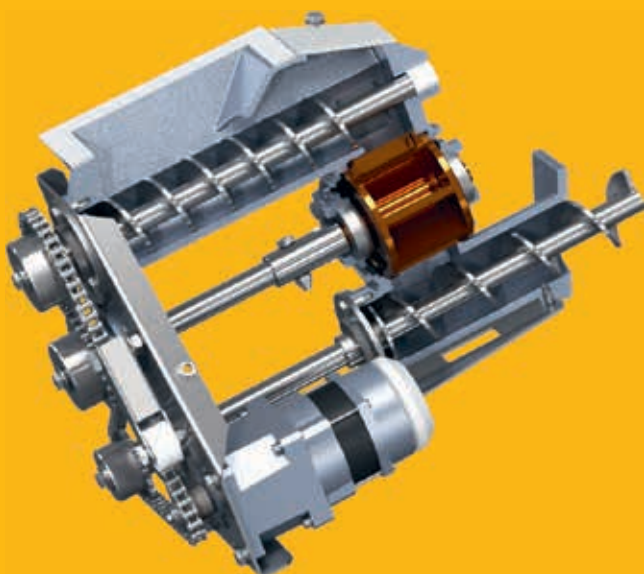

## Rotary valve

**The safe system.** The rotary valve absolutely protects you from burn-back: Burning should only take place in the combustion chamber and nowhere else.

A transport screw brings the pellets to the rotary valve – and only as many as the rotary valve can handle. This is why the pellets do not become wedged, crushed or broken. Thanks to this ETA developed system, the sealed edges of the rotary valve do not wear out. The system remains safe throughout the entire life of the boiler.



## Revolving grate with cleaning comb

**Clean burns well.** This patented system cleans the combustion chamber regularly of ash and slag – automaticall after 30 to 50 kg of burnt pellets. The air required for the combustion process is distributed equally between the clean grate segments. Additionally, the grate is constantly kept in slight motion. The gentle movement stokes the firebed and thus ensures even better combustion.

The ash is compacted and ends up in the 16 litre ash box. Even at full load operation, the boiler only has to be emptied from time to time. When it is time, the system sends an email or an SMS message. The information is also displayed on the touch display.

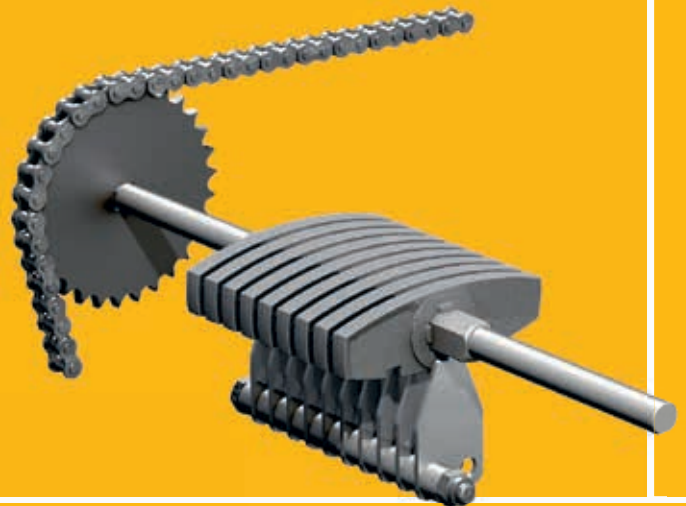

## Noiseless ceramic lighter ignition

**Sparking technology.** The energy expended for the ignition is much less in comparison with other ignition systems. The ignition itself works quicker.

## The way to heat

Two combustion chambers, one heat exchanger, one boiler: the ETA TWIN links a top-class pellet burner with a premier split log boiler. In order for both parts to work highly efficiently, all components must work together perfectly.

### Through the pellet burner:

- 1 Powerful vacuum turbine:** It transports the pellets from the store room to the intermediate hopper of the boiler.
- 2 Pellet bin:** Here, 60 kg of pellets are stored temporarily and are immediately available for use. So pellets have to be transported from the store room to the boiler only once or twice a day for 10 minutes. You control when that is.
- 3 Rotary valve as burn-back protection:** It is the completely sealed closing door between pellet store and combustion chamber and, therefore, safely protects against burn-back.
- 4 Pellet combustion chamber:** As pellets have different combustion properties than split logs, the highest efficiency can only be reached with separate combustion chambers.
- 5 Revolving grate with cleaning comb:** This patented system cleans the combustion chamber regularly of ash and slag.

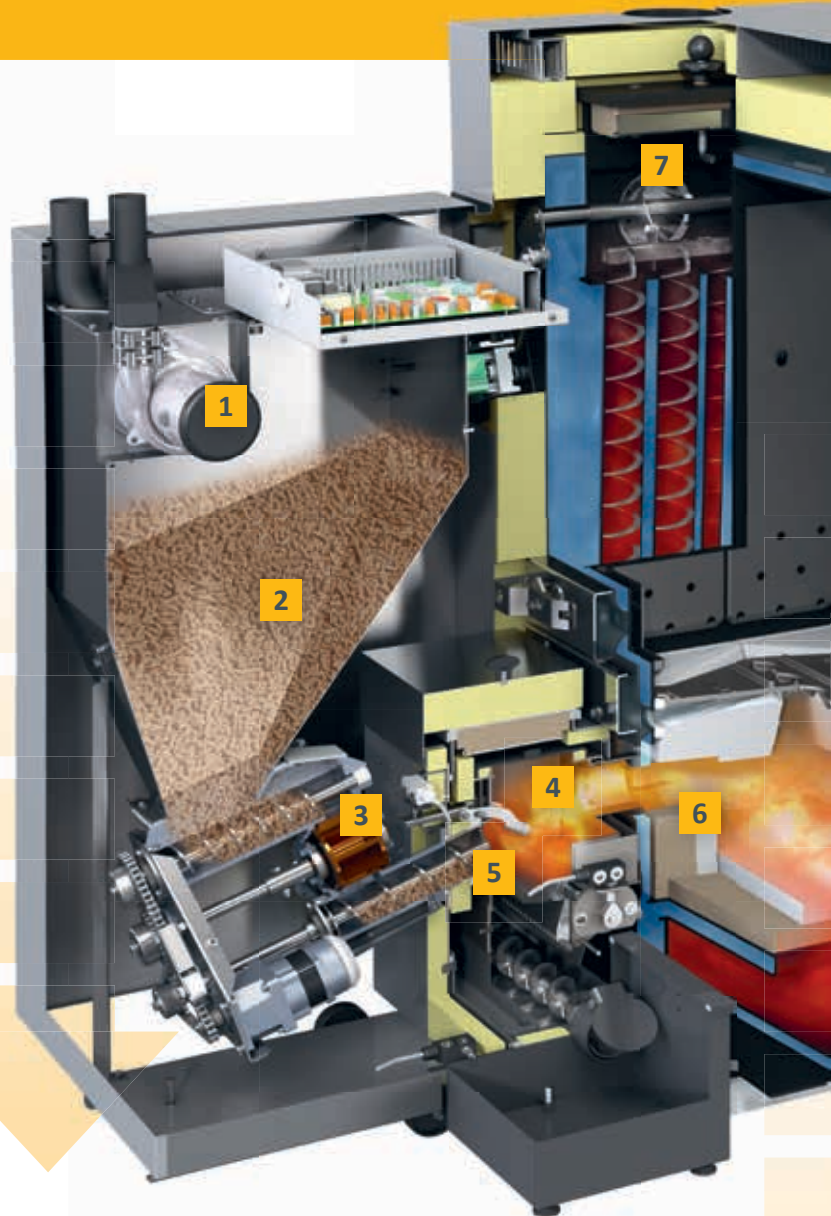

### Pellet burner and split logs boiler:

- 6 connection flange to glow zone combustion chamber:** This is where the combustion chambers for pellets and split logs are connected.
- 7 Draught fan:** Quiet as a whisper, this fan ensures underpressure in the boiler. Additionally, it controls the air quantity and thus ensures safety in the boiler room.





**Through the split log boiler:**

- 9 Insulation door:** Because you don't want to heat the cellar but rather the house, the insulated outer door protects against heat loss by radiation – and does so very well.
- 10 Large fuel chamber doors:** so that adding wood is really simple!
- 11 Carbonization gas extraction:** It is active when you add fuel and ensures that gas never escapes when the fuel chamber doors are open.
- 12 Large filling room:** thanks to a capacity of 150 litres, you only have to add fuel occasionally.
- 13 Temperature-resistant cast iron grates:** protect the parts of the combustion chamber that are most exposed to heat. This include air nozzles, which blow the oxygen required for combustion into the combustion chamber.
- 14 Patented glow zone combustion chamber:** it is especially heat-resistant and fitted with expansion joints, so that no cracks occur due to temperature fluctuations.
- 15 Touchscreen:** the capacitive touchscreen can be adjusted to the individual operator's comfort by tilting or swivelling.

**8 De-ashing, cleaning and maintenance from the front:** This is not only comfortable but also makes setting up the boiler in small boiler rooms easy. There are no lateral doors for which additional space is needed.

**The way through the boiler:**

-  Fuel
-  Flue gases
-  Heating water



## Perfect combination

The TWIN combines the advantages of a split log with those of a pellet boiler. If split logs are in the boiler, then this most economic fuel is used. If not, it still remains warm – thanks to flexibly adjustable switchover automation to fully automatic heating with pellets.

**Automatically always warm.** When the split logs run out in the boiler and it cannot produce any more heat, the system uses the heat stored in the buffer tank. If the energy stored there is also consumed it still won't get cold, thanks to the TWIN. Even if you don't add fuel. The pellet automation of the ETA TWIN simply takes over. You don't have to do anything, not even change the settings control system.

**The automation also works in reverse.** If you wish to use split logs even though the automatic pellet system is currently in use – no problem! As soon as you open the boiler's insulating door the pellet boiler switches off. You add wood, ignite it and the boiler carries on working.

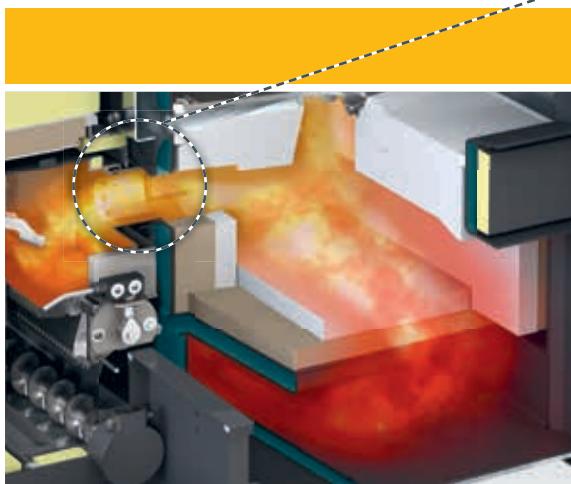
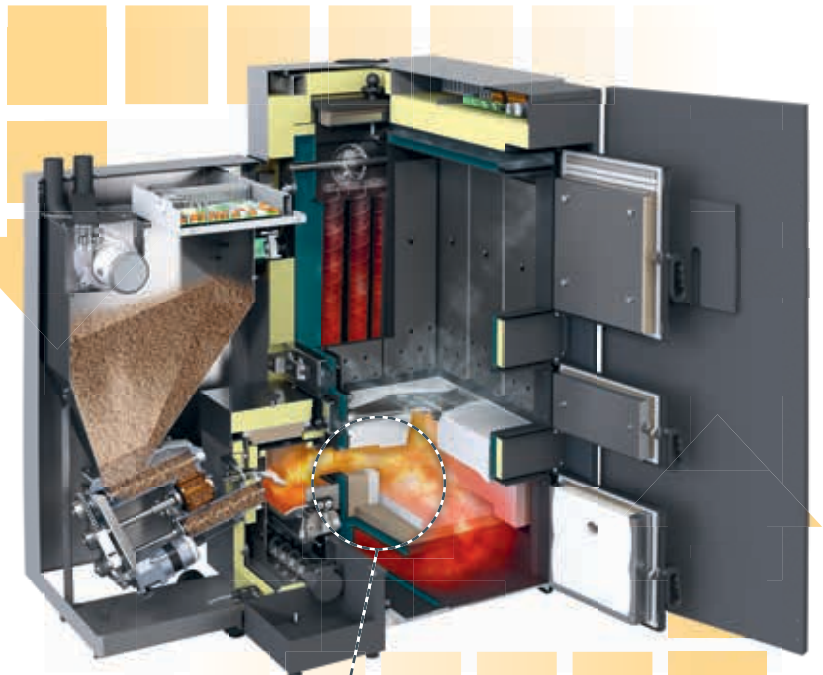

**Safe flame handling.** An important quality criteria for a combination boiler is optimum flame handling between the combustion chambers for pellets and split logs. It significantly increases the lifetime and efficiency of the boiler. With the ETA SH-TWIN, the opening is ideally dimensioned and positioned. The flames never come into contact with obstacles and can always ignite. The flame handling in areas of the boiler optimally protected against heat.





## Hopper for pellets

**Well prepared:** 60 kg of pellets are stored here temporarily and are immediately available for use. So pellets have to be transported from the store room to the boiler only once or twice a day for 10 minutes. You control when that is.

## One control system for the whole heating system

**Versatile, but not complicated.** Whether combustion control, pellet conveying, buffer management, hot water preparation, weather-compensated heating circuit controlled with a weekly program for two circuits or the connected solar heating system: all of this can be controlled via a touchscreen directly on the boiler or via the internet from any PC, smartphone or tablet. It is a lot, but it is easy to handle as the images on the touchscreen are self-explanatory.

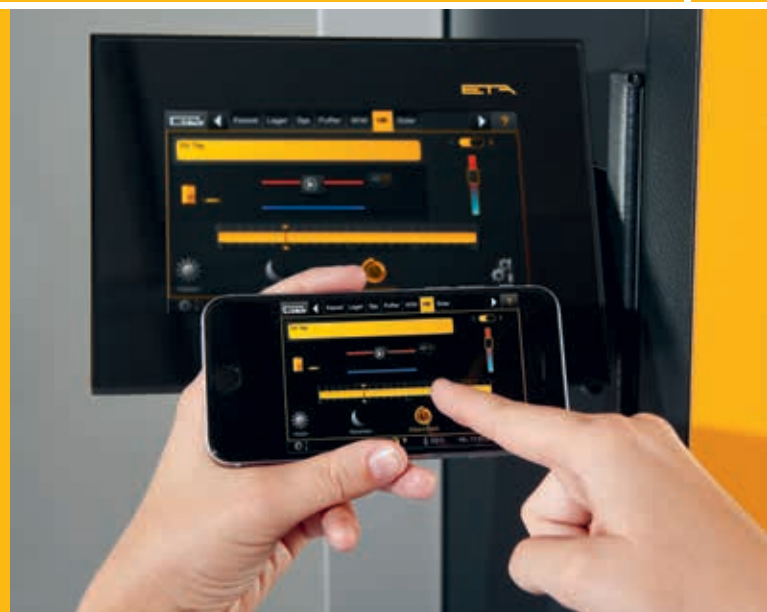

# Always space for pellets

The pellet store can easily be set up anywhere an oil tank has previously stood. It doesn't even have to be near the boiler, but can be situated up to 20 m away.

If the pellet store is located beneath the boiler, and if using a suitable conveying system, up to two storeys can be overcome. If there's no space in the house, the store room can also be set-up in an adjacent building or an underground tank can be used. The store room just needs to be dry so that the pellets don't swell up. Wooden cladding can help in damp rooms.

### A clean solution

The small pellets, which are pressed from the waste products of the wood industry, are delivered by tanker and blown into the store room. Thus, the delivery of pellets is an extremely clean process. If the store is sealed, then no dust can escape here either.



## How do the pellets get to the boiler?

### Discharge screw:

It stretches the entire length of the store room, can be up to 5 m long and transports the pellets from the store room to the transport hoses, which lead to the boiler. From here, the pellets are conveyed further with a vacuum turbine. After transport the hoses are vacuumed empty. Hence they do not clog up and always work with the highest degree of efficiency. With this standard system, the store room can be completely emptied.

Over the inclined smooth floor, the pellets automatically slide into the transport screw. The impact protection mat is suspended opposite the filling nozzles, so that the pellets do not shatter on the wall when they are blown into the store room from the truck. Prerequisite for this construction is that the connections for the transport hoses to the boiler are located on the narrow side of the store room, so that the whole length of the room can be used with the screw.

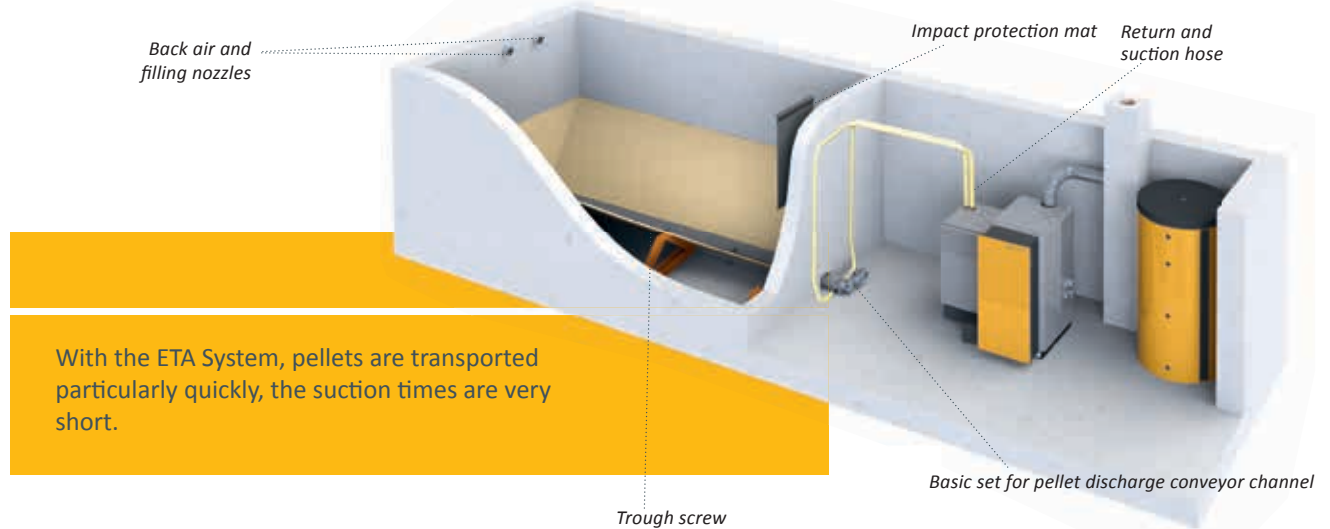

With the ETA System, pellets are transported particularly quickly, the suction times are very short.

### Suction probes:

If the shape of the room is not suitable for a discharge screw, the ETA suction probe system is the ideal choice. Here, the pellets slide over the slanting and smooth wooden floor directly to the four suction probes, which alternately transport pellets away from the store room. Through automatic changeover, the fuel supply is not interrupted if a probe doesn't get any pellets at a certain point in time. The prerequisite for this system is that the store room is situated opposite the boiler in the same storey or higher, and that the store room is no longer than 4 m. Unlike screws, the suction probes do not fully empty the store room. When the storage room capacity is tight, this can be a disadvantage. The advantage is that this system can be used even in angled store rooms.



With the suction probes, nearly all rooms can be used as a pellet store, even if the room is angular.

## How big does the store room have to be?

**Heating value** of the pellets = 4.9 kWh/kg

**Weight** of the pellets = 650 kg/m<sup>3</sup>

### Rule of thumb for the pellets required

9 kW heating load / 3 = 3 tonnes pellets annually

9 kW heating load / 2 = 4.5 cubic metres annually

**Don't have much space in the boiler room?** Do you mainly use split logs? Is your annual consumption of pellets low? Then perhaps you don't need a pellet store room, but only the manually fillable hopper from ETA. It's directly connected to the boiler with hoses. It is especially space-saving, as its footprint is only 58 x 70 cm. You can fill it with up to 260 kg bagged pellets and thus heat for about a week without adding fuel. Its capacity is thus significantly larger than that of the small intermediate hopper directly on the boiler.



### ETA tip: storage in the ETA Box

One particularly practical solution is the ETABox. It can be set up directly in the boiler room, in the attic, in a barn or – if covered – even outside. It even keeps the pellets dry in damp rooms. Distances of up to 20 meters of suction hose stretching from the box to the boiler are no problem. However the ETABox cannot be set up directly on the wall. Which is why the space required is a bit larger compared to a brick store with the same capacity.

The ETABox modular system is available in various sizes from 2 tonnes to 8.8 tonnes fill volume and can be installed in no time without a bricklayer or carpenter. What is important is that the room in which the box is located can be ventilated during filling.

If the ETABox is set up directly in the boiler room, the relevant regional building regulations must be taken into account. In most German states, up to 6.5 tonnes of pellets can be stored in the boiler room. In Austria, up to 9.75 tonnes is allowed in some states. In Switzerland, up to 6.5 tonnes of wood can be stored in separate boiler rooms, though the clearance from the boiler must be 1 m.

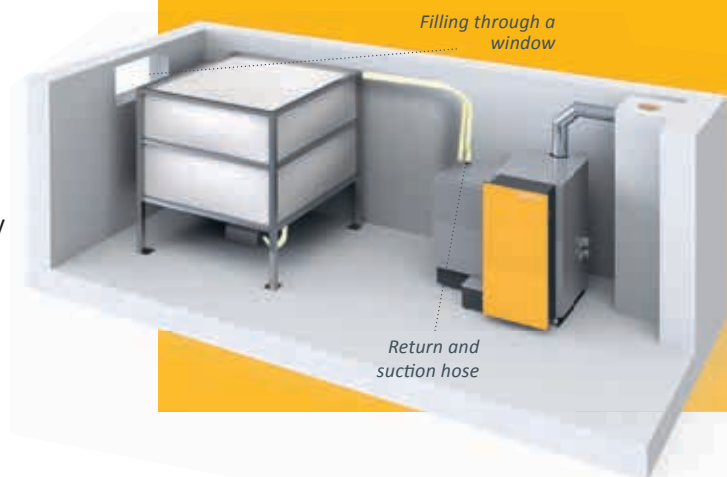



*Away mode, night time mode, vacation setting: intuitively, you know immediately which button does what.*

## Easy to control from anywhere

Good technology is characterized by its user friendliness. You don't have to be a technician to use the many functions of the ETAtouch.



*You can control the boiler via smartphone, PC or tablet as well as directly on the touchscreen.*

### **ETAtouch: the touchscreen on the boiler**

Confusingly arranged buttons and control systems are a thing of the past, because with the ETA SH-TWIN touchscreen you can quickly and easily control all settings. The icons are self-explanatory. Whether you generally want to make it warmer or cooler, change the time for night-time mode or want to switch to eco mode during your vacation - you will tap on the right symbol intuitively and completely without operating manuals!

You not only control your boiler via the touchscreen, but also have an overview of all connected components, such as buffer storage tank, pellet store, solar heating system or hot water preparation. You know straightaway, for example, how many pellets you still have in store or how effective your solar heating system was.

### **meinETA: the free internet platform**

If your heating boiler is connected to the internet, you can see and change all heating settings on your mobile, tablet or PC. So you always have a handle on

your heating, wherever you are! When you login to [www.meinETA.at](http://www.meinETA.at), you see the touchscreen as if you were standing right in front of the boiler!

The pellet store needs filling, the ash bin must be emptied, it's time for the next heating service... You don't have to remember all these things yourself. meinETA reminds you for free by email.

### **Quick help**

Give your installer or the ETA customer service representative temporary access rights to your meinETA account. So they can prepare for their visit. And maybe the technician doesn't even have to visit, because thanks to meinETA they can tell you over the phone what you need to do to make your boiler work again. You can see who can access your boiler via the status display. Only you decide who's in your partner network!



*Come home to a warm house: the boiler can also be controlled while you're on the go.*

**Technical requirements for meinETA**

To be able to use meinETA, you need a broadband connection in your home. The ETA boiler's touch screen is connected to the Internet via a network cable. And anyone who doesn't have a network connection in the basement simply connects via the ETA PowerLine. It efficiently transfers the data from any socket to the modem.

**For tablet, smartphone and PC**

meinETA runs on all current operating systems, such as iOS or Android. Via PC, meinETA can be loaded by any modern internet browser, such as Mozilla Firefox, Safari, Google Chrome or Internet Explorer 9.

**Integration into Building Management**

The integration into an on-site building management or master control system is unproblematic. Values can be queried and changed with RESTful web services and Modbus/TCP.



**There for you**

ETA devices are characterized by the highest quality. They feature patented systems developed in Austria. The entire assembly takes place in-house in Hausruckviertal, Austria. In the unlikely event of a breakdown, ETA customer service is on the spot quickly. An experienced, competent on-call team is available to you.

# Everything on one display: the ETA Standard

A modern heating system is only effective if it is well-controlled. ETAtouch takes care of that.

At no added cost, the ETAtouch control system already includes all functions for two heating circuits, hot water supply via tank or instantaneous hot water module, as well as for the integration of a solar heating system. All ETA heating boilers also come with a LAN connection as standard. If you connect the boiler to the internet, you can easily control all components from a PC, tablet or smartphone.

## Boiler and combustion regulation\*

Speed-controlling the several components save power. The lambda and ignition time regulation increases efficiency. All components relevant to operation are monitored.

## Buffer storage tank management\*\*

Three to five sensors in the tank control the heat generator in the system and distribute the energy to the different consumers. Using five sensors, cascading regulation, QM-Holz and peak load management are part of the ETA Standard.

## Hot water preparation\*

Is made possible both via the ETA instantaneous hot water module but also via the hot water tank or combination tank. For all variants, circulation pumps can be controlled with time and/or requirement programs.

## Solar heating systems\*\*

Single or double circuit solar heating systems with one or two tanks, zone loading via the ETA stratified charging module and also two collector fields as well as three consumers are controlled.

## Two weather-controlled mixing heating circuits\*\*

They run with a weekly program which allows many time windows and automatic and/or manual additional functions. The system can optionally be expanded with room sensors and remote control.



*Comprehensible also without the need for an operating manual: The symbols on the touchscreen are self-explanatory. So controlling the heating system becomes child's play.*

## Additional system functions

Detection of third-party heating devices, such as oil boilers, gas boilers, heat pumps and wood burning stoves, thermostat or differential temperature thermostat, external demand from external devices such as heating fans, control of transmission lines, with or without mixers, and also of heat transfer stations, single room control systems, for example.

## Wall-mounted control box for more complex systems

All control systems can be extended with wall-mounted control boxes, with or without touchscreen.

\*Control system and sensor included in standard delivery scope

\*\*Control system depends on configuration, sensors are available as accessory

# From Hausruckviertel to the world

ETA specialises in the manufacture of biomass heating, i.e. log, pellet and wood chip boilers. The most modern technologies combined with naturally growing resources.

## ETA is efficient

Technicians designate the efficiency of a heating system with the Greek letter  $\eta$ , pronounced „eta“. ETA boilers stand for more heat with less fuel consumption, environmental soundness and sustainability.

## Wood: old but excellent

Wood is our oldest fuel - and our most modern: There is a lot of history - from open fires in front of caves to modern biomass boilers. In the middle of the 20th century, the number of wood heating systems briefly fell. Oil heating became the new, hyped option. A brief interlude in comparison to the consistency of wood. Today, we know that heating with fossil fuel has no future. It contributes to global warming and harms the environment. Supply security is also not guaranteed in the long term, as fossil fuels are being depleted, aren't renewable and often come from unstable regions. While wood by contrast is a cheaper, locally grown, renewable raw material that does not pollute the climate when burnt. No wonder wood heating is booming!

## Comfort with many components

Since December 1998, the Upper Austrian company ETA has been designing and building a new generation of wood-fired boilers. They are full of patented technologies and the most modern control technology – making them easy to use. Convenience and efficiency make ETA products so popular around the world. With a production of over 10,000 boilers per year and a global export proportion of around 80%, ETA is one of the leading biomass boiler producers.

## You get more than just a boiler

Anyone who decides on a wood or pellet boiler from ETA is choosing sustainability. This is not just in terms of fuel, but encompasses responsibility across the board, with sustainable workplaces in the region. More than 200 employees in Hofkirchen an der Trattnach have the best working conditions – including an in-house restaurant, bright assembly and storage halls, a fitness room and a sauna. There is even a free electric charging station for electric cars, which is supplied by the in-house photovoltaic system. This also covers all the power needed of a production hall and thus saves around 230 tonnes of CO<sub>2</sub> per year.



# The ETA SH log boiler

- 1 Safety heat exchanger R1/2" outside thread
- 2 Return with R5/4" coupling
- 3 Flow with R5/4" coupling
- 4 Discharge with coupling R1/2"

The cleaning lever and actuators for the air valve can optionally be mounted on the left or right of the boiler.

Dimensions in parentheses apply for the boilers with 40-60 kW.

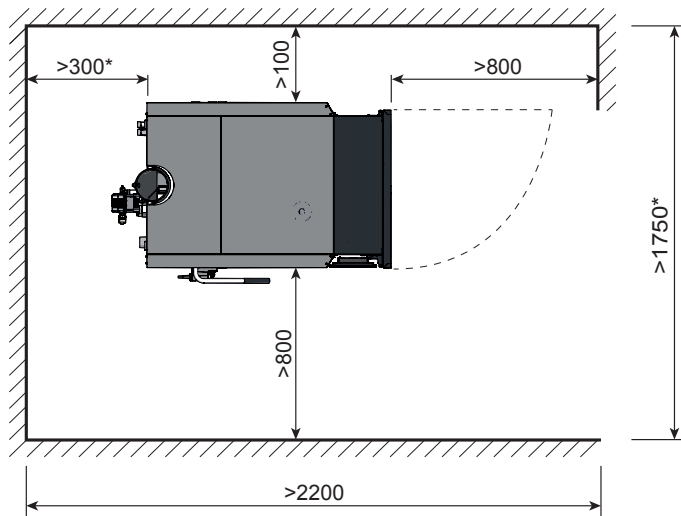
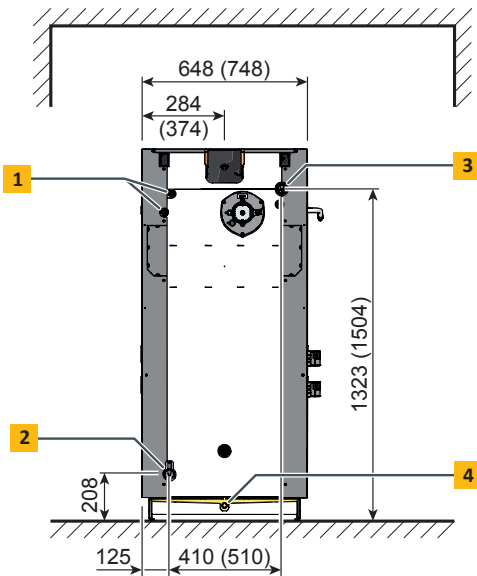
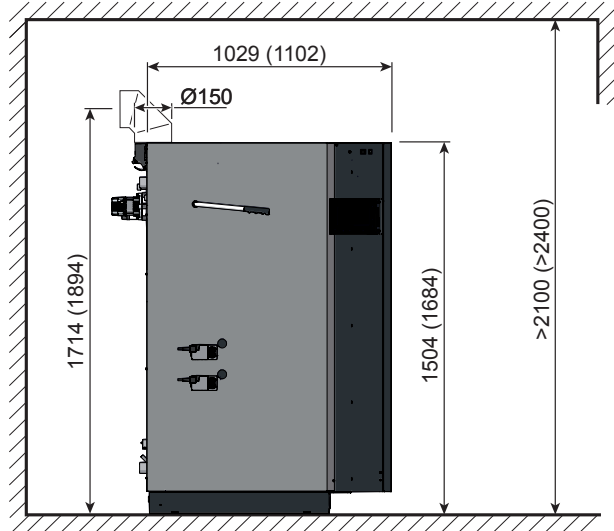

\*for later addition of a pellet burner ETA TWIN more space is needed!

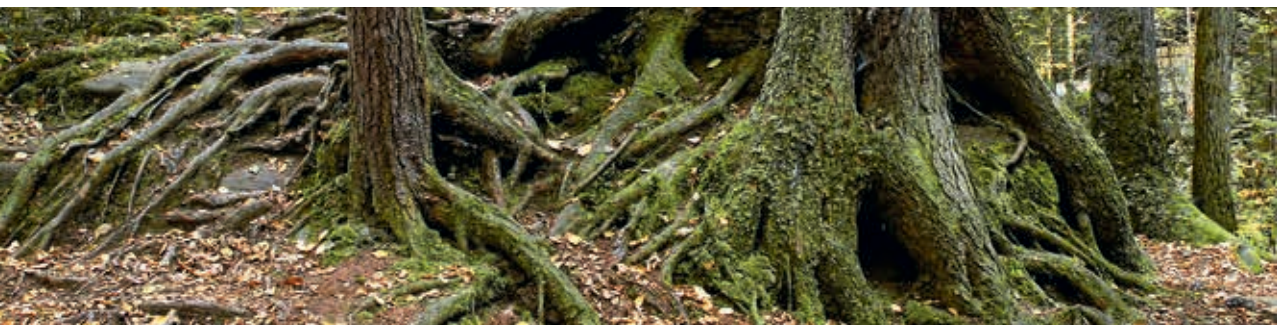





Log boiler	Unit	20 kW	30 kW	40 kW	50 kW	60 kW
Rated capacity	kW	10 - 20	15 - 30	20 - 40	20 - 49.9	20 - 60
Log efficiency at partial / full load*	%	95.4 / 91.6	92.7 / 89.3	93.6 / 91.4	93.6 / 91.4	93.6 / 91.4
Fuel chamber	mm	560 mm deep for 0.5 m logs, 340 x 365 mm door opening				
Fuel chamber volume	Litres	150		223		
Transport dimensions without panels, W x D x H	mm	588 x 940 x 1,495			688 x 1,015 x 1,675	
Weight	kg	580	583	791	793	795
Water content	Litres	110		170		
Water-side pressure drop ( $\Delta T=20\text{ }^{\circ}\text{C}$ )	Pa / mWS	190 / 0.019	370 / 0.037	220 / 0.022	340 / 0.034	480 / 0.048
Flue draught required at partial / full load	Pa	>2/>5 above 30 Pa a draught limiter is required				
Electrical power consumption at full load*	W	69	86	87		
Recommended buffer volume	Litres	>1,100, optimum 2,000			>2,200, optimum 3,000	
Required buffer volume in Germany (1. BImSchV)	Litres	1,100	1,650	2,200	2,750	3,300
Maximum permissible operating pressure	bar	3				
Temperature adjustment range	$^{\circ}\text{C}$	70 - 85				
Maximum permissible operating temperature	$^{\circ}\text{C}$	95				
Minimum return temperature	$^{\circ}\text{C}$	60				
Boiler class		5 acc. to EN303-5:2012				
Suitable fuels		Spruce and beech up to 20% water content				
Electrical connection		1 x 230 V / 50 Hz / 13 A				

\*Data from test reports by BLT Wieselburg



From 1/4/2017, biomass boilers of up to 70 kW will be labelled. The corresponding energy labels and required values for calculating an integrated production facility with biomass boiler can be viewed at [www.eta.co.at](http://www.eta.co.at).

# The ETA-TWIN combination boiler

- 1** Safety heat exchanger R1/2" outside thread
- 2** Discharge with R1/2" coupling
- 3** Return with coupling R5/4"
- 4** Flow with R5/4" coupling
- 5** Pellet suction hose DN50
- 6** Pellet return air DN50

The pellet burner can be delivered for installation on the right or left side.

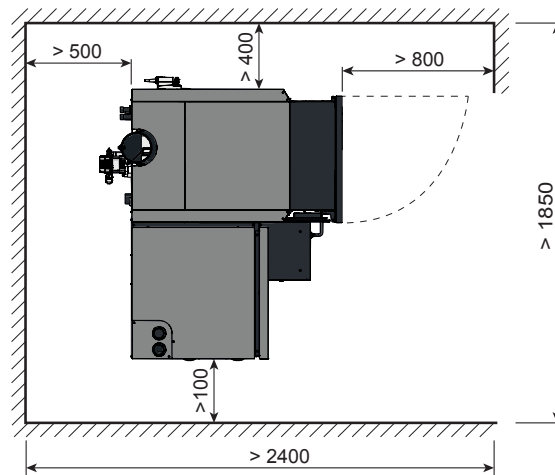
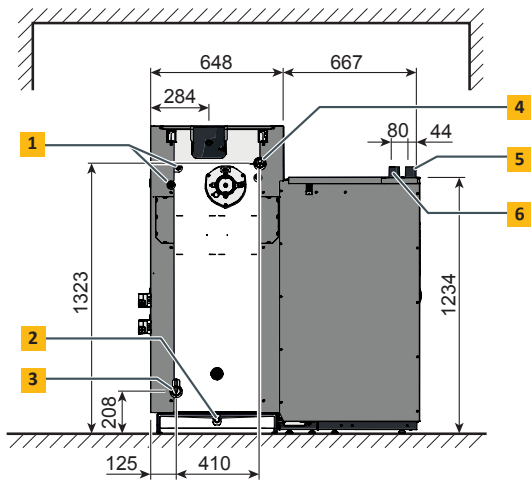
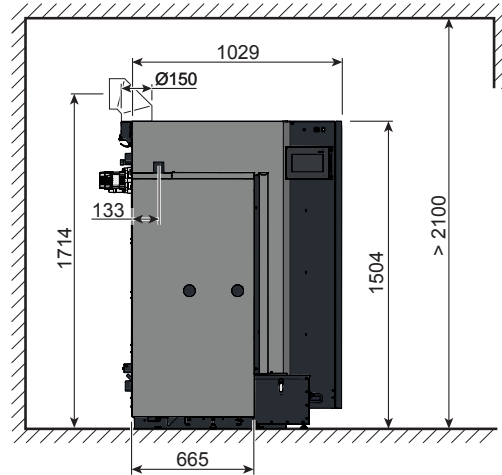



TWIN Pellet Burner	Unit	20 kW	26 kW
Rated capacity log boiler	kW	10 - 20	15 - 30
Rated capacity TWIN pellet burner	kW	6 - 20	7.5 - 26
Efficiency of the log boiler at partial / full load*	%	95.4 / 91.6	92.7 / 89.3
Efficiency of pellet burner at partial / full load*	%	87.8 / 92.0	87.7 / 91.5
Log boiler fuel chamber	mm	560 mm deep for 0.5 m logs, 340 x 365 mm door opening	
Log boiler fuel chamber volume	Litres	150	
Transport dimensions, W x D x H	mm	667 x 665 x 1,234	
Weight with/without pellet burner	kg	728 / 580	728 / 583
Water content	Litres	110	
Water-side pressure drop at $\Delta T=20\text{ }^{\circ}\text{C}$	Pa / mWS	190 / 0.019	370 / 0.037
Pellet bin on boiler (net)	kg	60 kg (294 kWh)	
Maximum distance to pellet store	m	20	
Ash box volume	Litres	16	
Flue draught required at partial / full load	Pa	>2/>5 above 30 Pa a draught limiter is required	
Electrical power consumption of pellet burner at partial / full load*	W	46 / 61	63 / 116
Recommended buffer volume	Litres	> 1,100, optimum 2,000	
Required buffer volume in Germany (1. BImSchV)	Litres	1,100	1,650
Maximum permissible operating pressure	bar	3	
Temperature adjustment range	$^{\circ}\text{C}$	70 - 85	
Maximum permissible operating temperature	$^{\circ}\text{C}$	95	
Minimum return temperature	$^{\circ}\text{C}$	60	
Boiler class		5 acc. to EN303-5:2012	
Suitable fuels		Spruce and beech up to 20% water content, pellets ENplus-A1, ISO 17225-2-A1	
Electrical connection		1x 230 V / 50 Hz / 13 A	

\*Data from test reports by BLT Wieselburg



From 1/4/2017, biomass boilers of up to 70 kW will be labelled. The corresponding energy labels and required values for calculating an integrated production facility with biomass boiler can be viewed at [www.eta.co.at](http://www.eta.co.at).



ETA PU PelletsUnit 7 to 15 kW



ETA PC PelletsCompact 20 to 50 kW



ETA PE-K Pellet Boiler 70 to 220 kW



ETA SH Wood Gasification Boiler 20 to 60 kW



ETA SH-P Wood Gasification Boiler 20 and 30 kW with ETA TWIN Pellet Burner 20 and 26 kW



ETA stratified buffer SP 500 to 5,000 lt and SPS 600 to 2,200 lt



ETA Hydraulic modules



ETA eHACK Wood Chip Boiler 20 to 45 kW



ETA HACK Wood Chip Boiler 70 to 200 kW



ETA HACK VR Wood Chip Boiler with moving grate 333-500 kW

Your heating specialist will be happy to advise you



ETA Heiztechnik GmbH  
Gewerbepark 1  
4716 Hofkirchen an der Trattnach, Austria  
Tel.: +43 (0)7734 2288-0  
Fax: +43 (0)7734 2288-22  
info@eta.co.at  
www.eta.co.at

**Technical changes reserved**

In order to provide you the benefits of our continuous development, we reserve the right to change specifications without prior notice. Printing and typesetting errors or changes of any kind made in the interim are not cause for claims. Individual configurations depicted or described here are only available as options. In the event of discrepancies between individual documents regarding the scope of delivery, the information provided in our current price list shall prevail. Images and symbols may contain options that are available for an additional cost.

Photo source: ETA Heiztechnik GmbH, Lothar Prokop Photographie, istockphoto, Thinkstockphotos, Photocase, Shutterstock.  
SH-TWIN ETA EN, 2017-02

